

Power Defense Molded Case Circuit Breakers—Frame Size 5

2



Contents

Description	Page
Power Defense Molded Case Circuit Breakers	
Frame Size 1 (15–125 A)	V4-T2-22
Frame Size 2 (15–225 A)	V4-T2-29
Frame Size 3 (45–600 A)	V4-T2-42
Frame Size 4 (300–800 A)	V4-T2-57
Frame Size 5 (320–1200 A)	
Catalog Number / Product Selection	V4-T2-71
Accessories	V4-T2-76
Dimensions and Weights	V4-T2-78
Frame Size 6 (700–2500 A)	V4-T2-79
Motor Circuit Protectors (3–600 A)	V4-T2-87
Motor Protection Circuit Breakers (15–600 A)	V4-T2-98
Terminals, Lugs and Connectors	V4-T2-104
Communications and Software	V4-T2-127
Special Applications	V4-T2-129

Power Defense Molded Case Circuit Breakers—Frame Size 5

Product Description

Frame Size 5 covers a global range of 320 A through 1200 A with a complete offering of advanced PXR electronic trip units. It includes two frame sizes of 800 A and 1200 A. Additionally, PD-5 has a 1600 A IEC (CE) and GB (CCC) frame that covers 800 A through 1600 A.

Application Description

Frame Size 5 can be used to meet a wide range of circuit protection and power distribution needs, including ground fault protection, 100% UL ratings, high interrupting capacity and high instantaneous settings for selective coordination. PXR trip units in PD-5 provide all levels of protection, including energy metering with multiple communication schemes, breaker health indication and arc flash reduction options.

Features and Benefits

Frame Size 5 breakers are modular and available as complete breakers from the factory or as modular components, including frames, trip units, accessories and terminals to provide flexibility for customers. PXR trip units are available with advanced features to provide customers unparalleled situational awareness of their electrical system.

Standards and Certifications

Power Defense breakers are designed and tested to meet stringent requirements for:

- UL
- CSA
- IEC (CE)
- CB (CCC)



Catalog Number / Product Selection

Power Defense—Frame Size 5 (320–1200 A) for UL/CSA and 320–1600 A for IEC/CCC)

Frame Size 5 covers a range of 320 A through 1200 A using electronic trip units. It is available in configurations of 2-pole, 3-pole and 4-pole, with the 2-pole being in the same physical size of a 3-pole variant. Additionally, an IEC / CCC option is available for 1600 A, with selectable ratings from 800 A through 1600 A.

Interrupting Ratings

	K		M		N		P		T	
ANSI (UL/CSA)	kA rms		kA rms		kA rms		kA rms		kA rms	
240 Vac	85		100		150		200		200	
480 Vac	50		65		85		100		150	
600 Vac	25		35		50		65		65	
IEC	I _{cu}	I _{cs}	I _{cu}	I _{cs}	I _{cu}	I _{cs}	I _{cu}	I _{cs}	I _{cu}	I _{cs}
240 Vac	85	85	100	100	150	100	200	150	—	—
380–415 Vac	50	50	70	53	70	50	100	50	—	—
440 Vac	35	35	50	40	70	50	100	50	—	—
480 Vac	35	22.5	50	30	65	40	85	40	—	—
525 Vac	25	20	30	25	35	25	40	25	—	—
660–690 Vac	10	5	15	7.5	20	10	35	18	—	—

Molded Case Circuit Breakers with Power Xpert Release (PXR) Electronic Trip Units (ETU)

This information is presented as a tool to develop catalog numbers for selecting Power Defense circuit breakers and trip units.

Molded Case Circuit Breakers with PXR ETU—Globally Rated

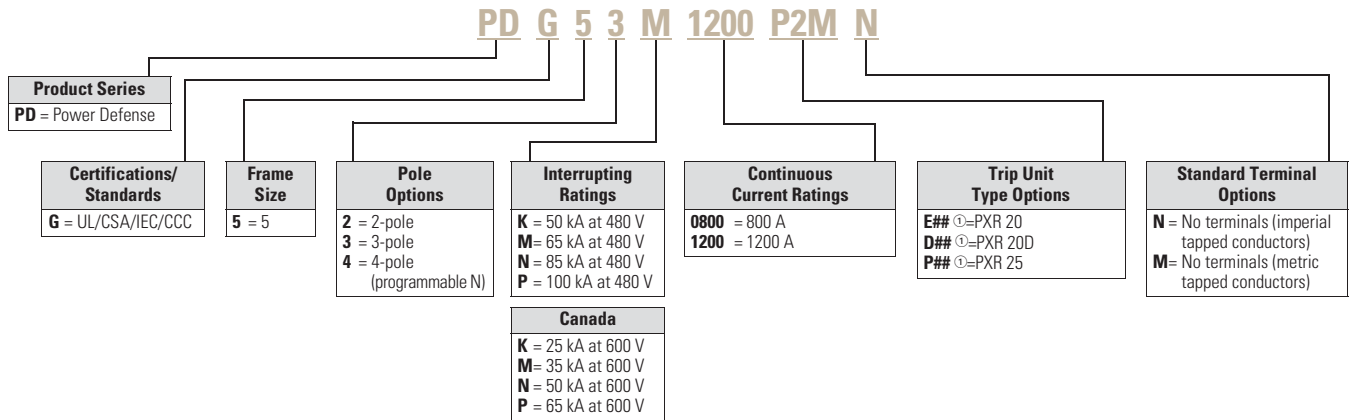

Molded Case Circuit Breakers with PXR ETU—Globally Rated (100% UL Rated)

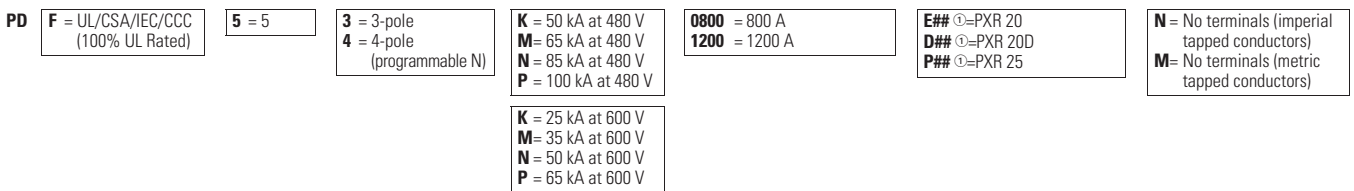

Molded Case Circuit Breakers with PXR ETU (150 kA at 480 V / 65 kA at 600 V)—UL/CSA Rated



Note

① See tables and descriptions on **Page V4-T2-74** for protection type (#₁) and available configured options (#₂).

2.2

Molded Case Circuit Breakers

Power Defense Molded Case Circuit Breakers

2

Molded Case Circuit Breakers with Power Xpert Release (PXR) Electronic Trip Units (ETU)

This information is presented as a tool to develop catalog numbers for selecting Power Defense circuit breakers and trip units.

Molded Case Switches—Globally Rated [Ⓛ]

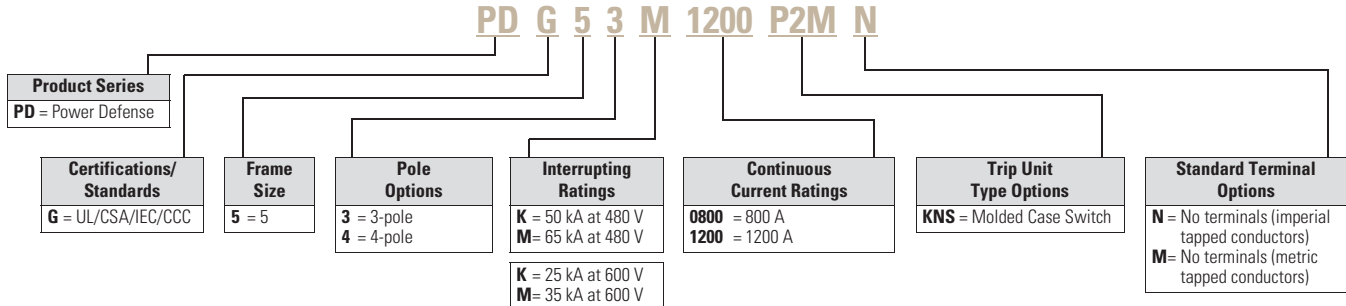

Molded Case Circuit Breakers—IEC/CCC Rated (only available as a complete breaker)

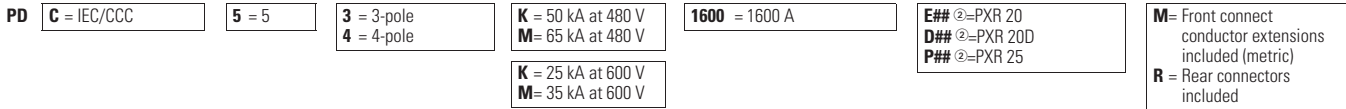

Globally Rated Frame Only

PD-5 electronic breakers may also be purchased as separate frames, trip units, terminals, and accessories for field configuration of a final breaker. Each Frame Only device is marked with interrupting ratings and a maximum continuous current rating; each trip unit is also marked with a maximum continuous current rating, which must not exceed that of the frame. Additionally, 100% UL Rated frames are marked as such on the Frame Only device.

This information is presented as a tool to develop catalog numbers for selecting Power Defense circuit breakers and trip units.

Frame Only—Globally Rated

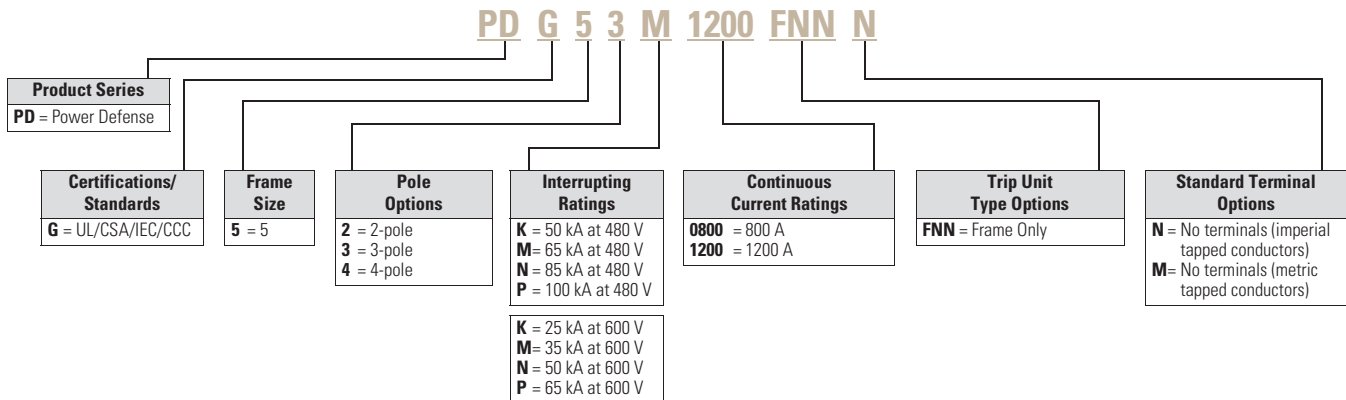

Frame Only—Globally Rated (100% UL Rated)

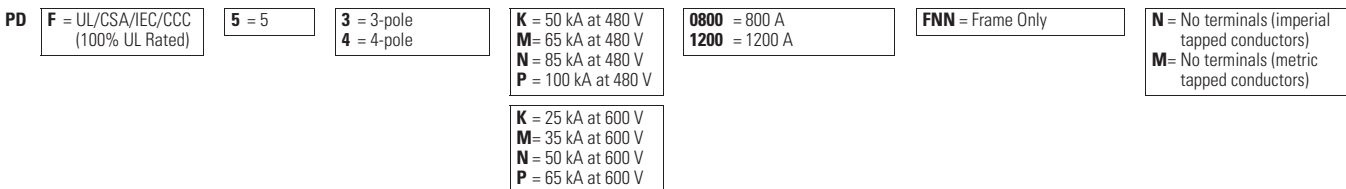

Notes

- Ⓛ Molded case switch may open above 14,000 A.
- Ⓜ See tables and descriptions on **Page V4-T2-74** for protection type (#₁) and available configured options (#₂).

Trip Units

PD-5 electronic breakers may also be purchased as separate frames, trip units, terminals, and accessories for field configuration of a final breaker. Each frame rating (800 A, 1200 A, and 1600 A—IEC only) must use trip units of the same rating. Additionally, for two-pole breakers, three-pole trip units are used.

PDG designated trip units are for use with PDG and PDF breaker frames. The 100% rating for PDF (100% UL Rated) is marked on the frame, not the trip unit.

Trip Units Only

This information is presented as a tool to develop catalog numbers for selecting Power Defense circuit breakers and trip units.

Power Xpert Release (PXR) Electronic Trip Units

Power Xpert Release (PXR) Electronic Trip Units

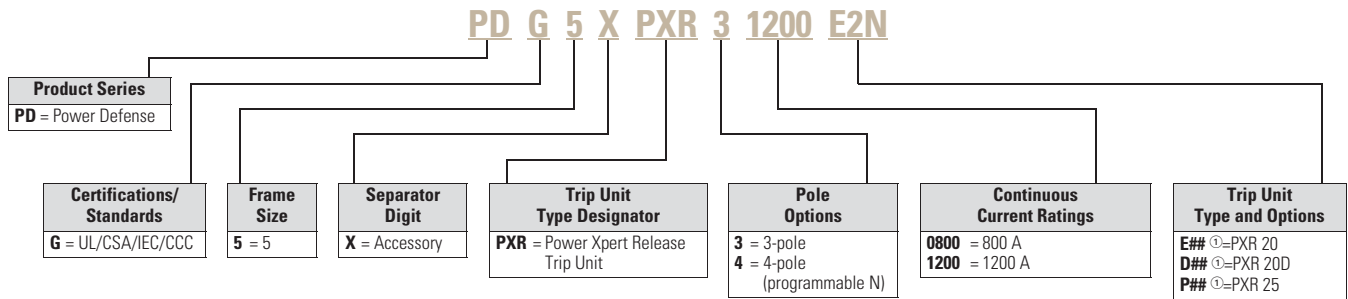

Note

① See tables and descriptions on **Page V4-T2-74** for protection type (#₁) and available configured options (#₂).

Power Xpert Release (PXR) Trip Unit Options—Frame Size 5

Power Xpert Release (PXR) Trip Unit Options

2

PXR	ETU	#(1)—Protection Type				#(2)—Available Configured Options								
		LSI	LSIG	LSI with ARMS	LSIG with ARMS	—	Relays	Relays Modbus	Relays	Relays	Relays Modbus	Relays	Relays Modbus	Relays Modbus
						—	—	—	ZSI	—	ZSI	—	ZSI	—
						—	—	—	—	CAM	—	CAM	—	CAM
PXR 20	E	2	—	—	—	N	R	M	Z	C	W	X	—	—
		—	3	4	5	—	R	M	Z	C	W	X	—	—
PXR 20D	D	2	3	4	5	—	—	M	—	—	W	—	D	Y
PXR 25	P	2	3	4	5	—	—	M	—	—	W	—	D	Y

Descriptions of PXR Configured Options

Relays—3 Form A contacts (rated for 240 Vac, 1 A)

- Interface: 3 wires (ALM1, ALM2, ALM Common)
- Programmable to indicate breaker conditions
- Available as field-installable option if not pre-configured (catalog number **PDG56XRELAYS**)

Modbus—Modbus RTU directly from breaker

- Interface: 3 wires (MODBA, MODBB, MODBG)
- No additional modules required
- Available as field-installable option if not pre-configured (catalog number **PDG56XMODRTU**)

ZSI—Zone Selective Interlocking

- Interface: 3 wires (Zin, Zout, Zcomm)
- Includes ability to turn ON and OFF, and indicate signals

CAM—CAM Link connection (requires a CAM module per breaker)

- Interface: 5 wires (refer to CAM IL for details)
- Communications Adapter Modules available for ModbusTCP and PROFIBUS

ARMS—Arcflash Reduction Maintenance System, or Maintenance Mode

- Available as trip unit Protection Type 4 or 5
- Interface: Switch and LED on face of trip unit and two wires for remote switch enable option (24 Vdc required)
- A programmable relay will be factory defaulted to remote indication of ARMS

Auxiliary Power

- Connection included with all PXR 20, 20D, and 25 trip units
- Required for communications, relays, and metering accuracy
- 24 Vdc, 0.5 A
- Interface: 2 wires (Aux + 24 V, Aux 0 V)

Available Continuous Current (I_r) Settings on PXR Electronic Trip Units

Catalog Number Selection and Maximum Setting (I_n)

Option	Setting	1600 A (IEC only)		
		0800 800 A	1200 1200 A	1600 1600 A
PXR 20	1	320 A	500 A	800 A
	2	350 A	550 A	900 A
	3	400 A	600 A	1000 A
	4	450 A	630 A	1100 A
	5	500 A	700 A	1200 A
	6	550 A	800 A	1250 A
	7	600 A	900 A	1300 A
	8	630 A	1000 A	1400 A
	9	700 A	1100 A	1500 A
	10 = I _n	800 A	1200 A	1600 A

PXR 20D, PXR 25 Programmable from minimum to maximum values in 10 A increments.

Terminals—Frame Size 5

Terminals for Frame 5 are available as single terminals only, unless otherwise specified. To configure both line and load of a 3-pole breaker, order quantity 6 terminals.

Terminal Types

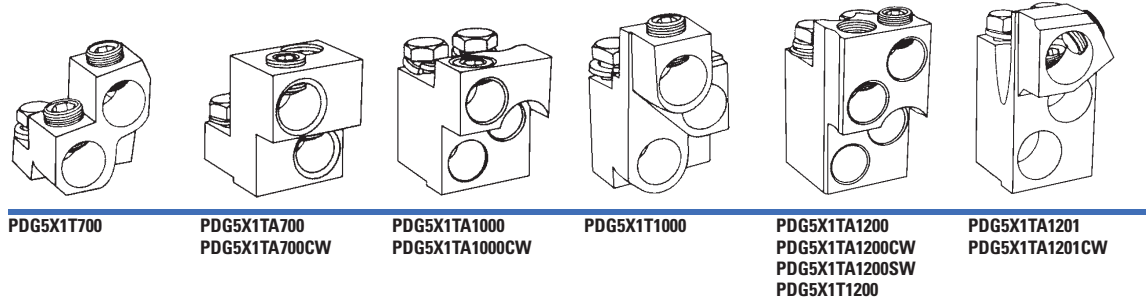

Note: Pictures are for reference only.

Terminals

Maximum Breaker Amperes	Terminal Body Type	Wire Type	Wire Class	Number of Conductors per Phase	AWG / kcmil Range per Conductor	Metric (mm ²) Range per Conductor	3-Pole Catalog Number ^①	Hardware Included
Aluminum Terminal Options								
700	Aluminum	Cu/Al	B, C	2	1–500	42.4–253	PDG5X1TA700	Imperial
1000	Aluminum	Cu/Al	B, C	3	3/0–400	85–203	PDG5X1TA1000	Imperial
1200	Aluminum	Cu/Al	B, C	4	4/0–500	107–253	PDG5X1TA1200	Imperial
1200	Aluminum	Cu/Al	B, C	3	500–750	253–380	PDG5X1TA1201	Imperial
Copper Terminal Options								
700	Copper	Cu	B, C	2	2/0–500	67.4–253	PDG5X1T700	Imperial
1000	Copper	Cu	B, C	3	3/0–500	85–253	PDG5X1T1000	Imperial
1200	Copper	Cu	B, C	4	3/0–400	85–203	PDG5X1T1200	Imperial
StrandAble Terminal Options								
1200	Aluminum	Cu/Al	B, C D, G, H, I, K, M	4	4/0–500 4/0–350	107–253 107–177	PDG5X1TA1200SW	Imperial
Control Wire Terminal Options								
700	Aluminum	Cu/Al	B, C	2	1–500	42.4–253	PDG5X1TA700CW	Imperial
1000	Aluminum	Cu/Al	B, C	3	3/0–400	85–203	PDG5X1TA1000CW	Imperial
1200	Aluminum	Cu/Al	B, C	4	4/0–500	107–253	PDG5X1TA1200CW	Imperial
1200	Aluminum	Cu/Al	B, C	3	500–750	253–380	PDG5X1TA1201CW	Imperial
Conductor Extensions ^{②③}								
1200	—	—	—	—	—	—	5104A24G01	Imperial 2-pole
1200	—	—	—	—	—	—	5104A24G02	Imperial 3-pole
1200	—	—	—	—	—	—	5104A24G05	Imperial 4-pole
1200	—	—	—	—	—	—	5104A24G03	Metric 2-pole
1200	—	—	—	—	—	—	5104A24G04	Metric 3-pole
1200	—	—	—	—	—	—	5104A24G06	Metric 4-pole

Note: Wire capacity is based on standard imperial wire sizes; metric sizes provided in table are a direct conversion to demonstrate maximum capacity, not to denote metric wire sizes.

Notes

- ① Add M at end for metric hardware.
- ② Included with 100% rated breaker.
- ③ Kits include conductors for both sides of the breaker (e.g., 6 conductors for a 3-pole breaker). Order quantity 1 per breaker.

Accessories

2

Internal Accessory Configurations—Frame Size 5

3- and 4-Pole Circuit Breakers

Tripping Accessory Options

	Left Pole	Right Pole
None	None	Bell Alarm Options ①
Shunt Trip	Bell Alarm Options ① Auxiliary Switch Options ① Alarm and Auxiliary Combination Options ①	Auxiliary Switch Options ① Bell and Auxiliary Combination Options ①
UVR		



Indicating Accessories—Frame Size 5

Alarms and Auxiliary Switches

Alarm Switch		Auxiliary Switch				
		None	None	1 Form C	2 Form C	3 Form C
None	Left	—	—	PDG5X1AC	PDG5X2AC	PDG5XL3AC
	Right	—	—	PDG5X1AC	PDG5X2AC	PDG5XR3AC
1 Form C	Left	—	PDG5XL1BC	PDG5XL1AC1BC	PDG5XL2AC1BC	—
	Right	—	PDG5XR1BC	PDG5XR1AC1BC	PDG5XR2AC1BC	—
2 Form C	Left	—	PDG5XL2BC	PDG5XL1AC2BC	—	—
	Right	—	PDG5XR2BC	PDG5XR1AC2BC	—	—

Alarm and Auxiliary Switches for Breakers with Communicating Trip Units ②

Alarm Switch		Auxiliary Switch			
		None	None	1 Form C	2 Form C
None	Left	—	—	—	—
	Right	—	PDG5XRCBSM	PDG5XRC1AC	PDG5XRC2AC
1 Form C	Left	—	—	—	—
	Right	—	PDG5XRC1BC	PDG5XRC1AC1BC	—
2 Form C	Left	—	—	—	—
	Right	—	PDG5XRC2BC	—	—

Notes

- ① See Indicating Accessories tables for options.
- ② All electronic trip units configured with communication will automatically include a communication indicator in the right pole. Up to two additional Form C contacts are available for external indication in the right pole.

Factory Installed Indicating Accessories—Frame Size 5^①**Alarms and Auxiliary Switches**

		Auxiliary Switch				
		None	None	1 Form C	2 Form C	3 Form C
Alarm Switch	None	Left	—	—	—	A4
		Right	NN	AC	A1	—
	1 Form C	Left	—	—	—	—
		Right	BC	CC	C1	—
	2 Form C	Left	—	—	—	—
		Right	B1	CX	—	—

Alarm and Auxiliary Switches for Breakers with Communicating Trip Units^②

		Auxiliary Switch			
		None	None	1 Form C	2 Form C
Alarm Switch	None	Left	—	—	—
		Right	NN	AC	A1
	1 Form C	Left	—	—	—
		Right	BC	CC	—
	2 Form C	Left	—	—	—
		Right	B1	—	—

Tripping Accessories—Frame Size 5**Shunt Trips**

Voltage	Pigtail (29 in / 0.75 m)	Factory Installed Catalog Number (Digit 17–18)
48–60 Vdc	PDG5XST60DCS	SK
110–125 Vdc	PDG5XST125DCS	SL
220–250 Vdc	PDG5XST250DCS	SM
24 Vac/Vdc	PDG5XST24ACDCS	SN
48–60 Vac	PDG5XST60ACS	ST
110–240 Vac	PDG5XST240ACS	SA or SB
380–440 Vac	PDG5XST440ACS	SC
480–600 Vac	PDG5XST600ACS	SD or SE

Undervoltage Releases (UVRs)

Voltage	Pigtail (29 in / 0.75 m)	Factory Installed Catalog Number (Digit 17–18)
12 Vdc	PDG5XUV12DCU	UH
24 Vdc	PDG5XUV24DCU	UG
48–60 Vdc	PDG5XUV60DCU	UJ or UK
125 Vdc	PDG5XUV125DCU	UL
250 Vdc	PDG5XUV250DCU	UM
12 Vac	PDG5XUV12ACU	UU
24 Vac	PDG5XUV24ACU	UF
48–60 Vac	PDG5XUV60ACU	UT
110–127 Vac	PDG5XUV120ACU	UA
208–240 Vac	PDG5XUV240ACU	UB
380–500 Vac	PDG5XUV480ACU	UC or UV

Note: Use PDG5XUV18DCU (Suffix US) when using Time Delay UVR.

Notes

- ① Factory installation of indicating accessories available for the right pole only. Left pole accessories may be field installed.
- ② All electronic trip units configured with communication will automatically include a Communication Indicator in the right pole. Up to two additional Form C contacts are available for external indication in the right pole.

Handle Mechanisms—Size 5**Variable Depth Rotary Handle Mechanism**

Description	NEMA 1/3R/12/4/4X Catalog Number	Factory Installed Digits 19–20
Standard lockable handle and mechanism	PDG5XHMDS	DA
Emergency lockable handle and mechanism	PDG5XHMDE	D1
12 in (305 mm) handle mechanism shaft	PDG56XHMS305	—

Flex Shaft Handle Mechanism

Cable Length (ft)	Metal Handle, NEMA 1/3R/12 Catalog Number	High Performance Handle, NEMA 1/3R/12 Catalog Number	Metal Handle, NEMA 4/4X Catalog Number	High Performance Handle, NEMA 4/4X Catalog Number
4 ft	PDG5XFS04	PDG5XFS04HP	PDG5XFS04X	PDG5XFS04HPX
5 ft	PDG5XFS05	PDG5XFS05HP	PDG5XFS05X	PDG5XFS05HPX
6 ft	PDG5XFS06	PDG5XFS06HP	PDG5XFS06X	PDG5XFS06HPX
10 ft	PDG5XFS10	PDG5XFS10HP	PDG5XFS10X	PDG5XFS10HPX

External Accessories—Frame Size 5**External Accessories**

Description	Fit Type	Catalog Number	Factory Installed Digits 19–20
Padlockable hasp	Left-side	PDG5XPLKS	L5
	Right-side		L6
Padlockable hasp	Top	PDG5XPLKT	L4
Padlockable hasp, OFF only	Top	PDG5XPLKTOFF	L1
Non-padlockable handle block	Field	PDG5XHB	—
Kirk key interlock kit ^①	Left-side	PDG5XKLKPSF	L8
	Right-side		L9
Walking beam interlock ^{②③}	Three- or four-pole	PDG5XWBI34P	WB ^④
Electrical operator	24 Vdc	EOP5T21	MG
	48 Vdc	EOP5T22	MJ
	125 Vdc	EOP5T26	ML
	120 Vac	EOP5T07	MA
	208 Vac	EOP5T09	MY
	240 Vac	EOP5T11	MB
Neutral CTs for ground fault (PXR)	Bus bar type	EOP5T15	MD
		PDG5XNCTB1200	—
Interphase barriers	Three-pole	PDG5XIB3P	—
	Four-pole	PDG5XIB4P	—
Terminal covers	Three-pole	PDG5XTC3P	—
Service entrance barrier kit	Three-pole	PRLSEBPD5	—

Base Mounting Hardware

Description	Catalog Number
Two-, three-, four-pole metric	BMH5M
Two-, three-, four-pole English	BMH5

Note: Base mounting hardware is included with a circuit breaker or molded case switch.

Dimensions and Weights—Frame Size 5**Approximate Dimensions in Inches (mm)**

Number of Poles	Width	Height	Depth
2	8.25 (209.5)	16 (406.4)	5.50 (139.7)
3	8.25 (209.5)	16 (406.4)	5.50 (139.7)
4	11.13 (282.7)	16 (406.4)	5.50 (139.7)

Approximate Shipping Weight in lb (kg)

Breaker Type	2-Pole	3-Pole	4-Pole
PDG5 800, 1200 and 1600 A	46.8 (21.30)	46.8 (21.30)	58 (26.31)

Notes

- ① Provision only. For use with Type F Kirk keylock (sold separately). Bolt projection in withdrawn position is 0.375 in (9.525 mm).
- ② Breaker must be ordered with walking beam interlock ready modification from plant (factory suffix "WB").
- ③ Requires two breakers.
- ④ Modification code for walking beam denotes modification to the breaker; accessory must be ordered separate.